

# HOTPOINT-BANDMASTER

## Models F55DBV & D35DBV

FIVE VALVE, TWO BAND, BATTERY-VIBRATOR OPERATED SUPERHETERODYNE

### TECHNICAL INFORMATION & SERVICE DATA

#### ELECTRICAL SPECIFICATIONS.

FREQUENCY RANGES ..... Medium Wave, 1600-550 Kc.  
(187.5-545 M.)

Short Wave, 22-7 Mc. (13.6-43 M.)

INTERMEDIATE FREQUENCY 455 Kc.

#### BATTERY COMPLEMENT:

There are three modes of operation—two employing "B" batteries and the third a Vibrator Power Unit.

Battery cables are available fitted with telephone tips for batteries fitted with Fahenstock clips, or with plugs for socket-type batteries.

The batteries used and their respective cables are as follows:—

Battery Operation:	Cable with Tips	Cable with Plugs
(1) 1—4 volt accumulator 2—45 volt "B" batteries	} 19183	} 19803
(2) 1—1.5 dry cell "A" battery 2—45 volt "B" batteries		

NOTE: If a 1.5 volt dry cell "A" battery is used it is necessary, if dial illumination is required, to remove the dial lamp cable from the terminals at the rear of the chassis and to connect the cable to the outer terminals of a 4.5 volt battery—see diagram, "Battery Connections."

#### Vibrator Power Unit Operation:

1—4 volt accumulator. Vib. Power Unit 19190.

#### BATTERY CONSUMPTION—

##### Battery Operation:

4 volt "A" battery .....	0.2 Amp.
1.5 volt "A" battery .....	0.3 Amp.
"B" battery .....	12 mA.

Vibrator Operation ..... 0.8 Amp.

DIAL LAMP (2) ..... 2.0 volt, 0.06 Amp.

#### FUSE:

Battery Operation .....	$\frac{1}{4}$ Amp.
Vibrator Operation .....	3 Amp.

#### VALVE COMPLEMENT:

- |                          |   |
|--------------------------|---|
| (1) 1A7GT Converter      | (3) IP5GT I.F. Amplifier                      |
| (2) IP5GT I.F. Amplifier | (4) 1H5GT Detector, A.V.C. and A.F. Amplifier |
| (5) 1Q5GT Output         |   |

VIBRATOR ..... A.W.A.-OAK Type, V6804

#### LOUDSPEAKER (Permanent Magnet)—

Model F55DBV.	Model D35DBV.
7 inch ..... Code No. AY23	12 inch ..... Code No. AU25
Transformer XA7	Transformer TX8
V.C. Impedance—	V.C. Impedance—
3 ohms at 400 C.P.S.	2.2 ohms at 400 C.P.S.

UNDISTORTED POWER OUTPUT ..... 250 Milliwatts

#### CONTROLS

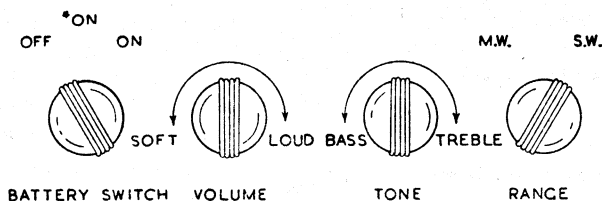

\* THE DIAL IS ILLUMINATED IN THIS POSITION

## D.C. RESISTANCE OF WINDINGS.

Winding	D.C. Resistance in ohms
Aerial Coil (M.W.)—	
Primary (L2)	10.5
Secondary (L3)	3.5
Aerial Coil (S.W.)—	
Primary (L4)	2
Secondary (L5)	*
Oscillator Coil (M.W.)—	
Primary (L6)	1
Secondary (L7)	6
Oscillator Coil (S.W.)—	
Primary (L8)	*
Secondary (L9)	*
I.F. Transformer Windings	7.5
I.F. Filter (L1)	17.5†
Smoothing Choke (L16)	*
Smoothing Choke (L75)	200
R.F. Filter Choke (L17, L73, L74)	*
R.F. Filter Choke (L71, L72)	9
Loudspeaker Input Transformer (T1)—	
XA7 Primary	650
XA7 Secondary	*
TX8 Primary	430
TX8 Secondary	*
Vibrator Transformer (T71)—	
Primary	*
Secondary	300

The above readings were taken on a standard chassis, but substitution of materials during manufacture may cause variations, and it should not be assumed that a component is faulty if a slightly different reading is obtained.

\* Less than 1 ohm.

† In some receivers this reading may be as high as 60 ohms.

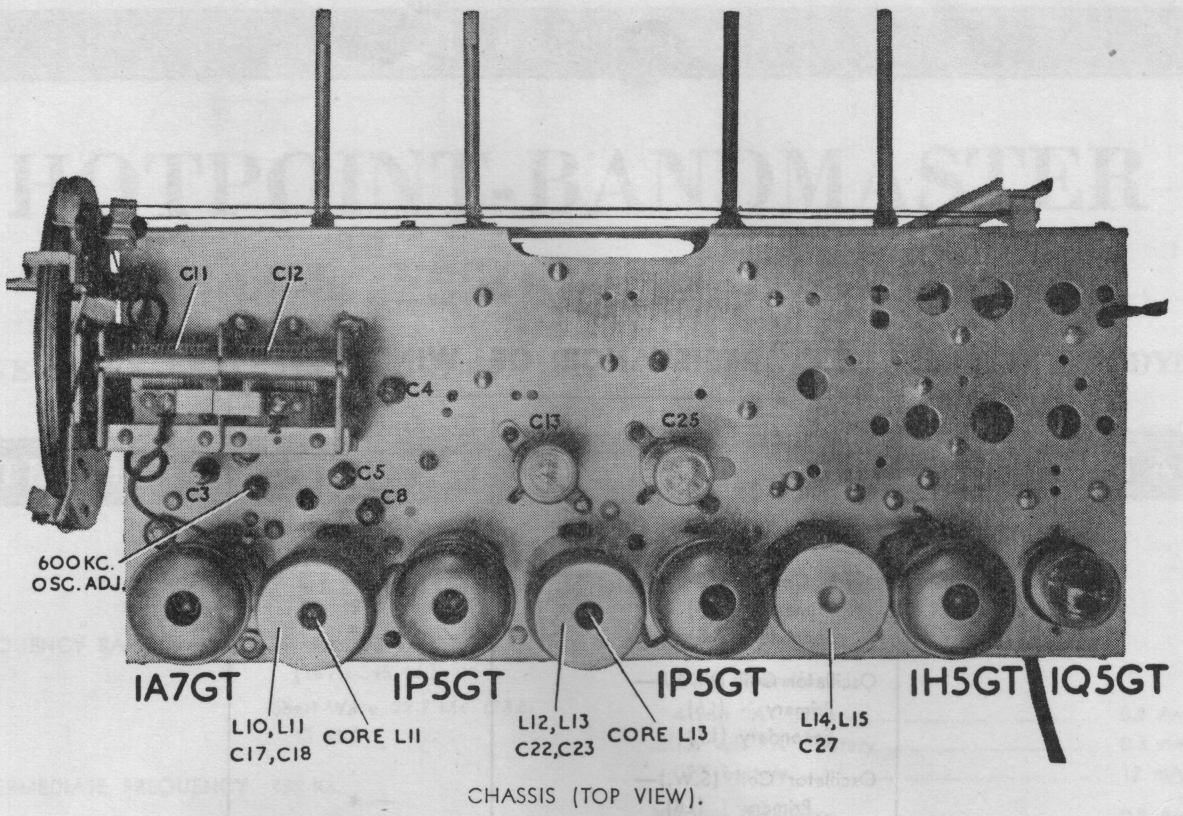

CHASSIS (TOP VIEW).

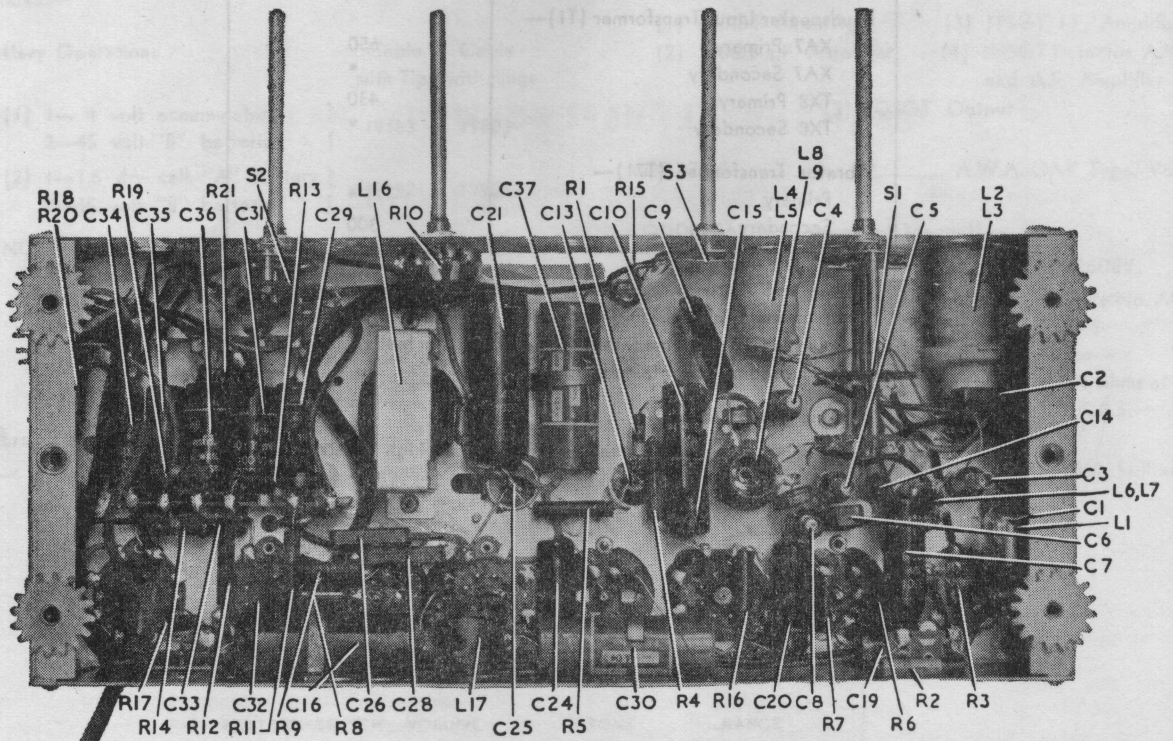

CHASSIS (UNDERNEATH VIEW).

# MECHANICAL SPECIFICATIONS.

	Height	Width	Depth
Cabinet Dimensions (inches)—			
F55DBV .....	11 $\frac{3}{8}$	23 $\frac{3}{4}$	10 $\frac{3}{8}$
D35DBV .....	33 $\frac{3}{8}$	30 $\frac{1}{2}$	13 $\frac{3}{8}$
Chassis Base Dimensions .....			
	3	15	6 $\frac{1}{2}$
Overall Chassis Height (inches) .....			8

	Height	Width	Depth
Carton Dimensions (inches)—			
F55DBV .....	12 $\frac{3}{4}$	25 $\frac{1}{2}$	11 $\frac{3}{4}$
D35DBV .....	34	31 $\frac{1}{2}$	16 $\frac{1}{2}$
Weight (nett lbs.)—			
F55DBV .....			30
D35DBV .....			70
Cabinet Finish .....	Walnut Veneer		

## GENERAL DESCRIPTION.

The Models F55DBV. and D35DBV. are table and console models, respectively, and employ the same chassis. They may be either battery or vibrator operated, and for battery operation either a 4-volt accumulator, or 1.5-volt dry-cell "A" battery may be used, the necessary circuit modification being effected by the battery cable employed.

Battery connections are shown in the accompanying diagram.

Design features include: Tropic-proof construction, automatic volume control, straight-line, edge-lighted dial, with Metropolitan stations printed in  $\frac{1}{8}$ -inch high characters; Magnetite cores in I.F. transformers and broadcast oscillator coil, air-dielectric trimming capacitors, broadcast tuning range extended to 1600 Kc. to permit reception of proposed stations above 1500 Kc.

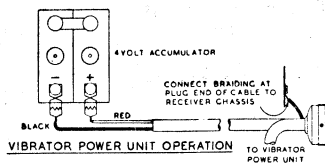
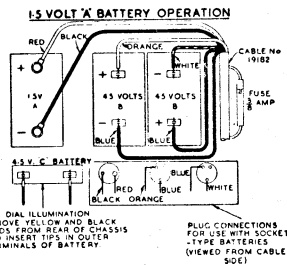
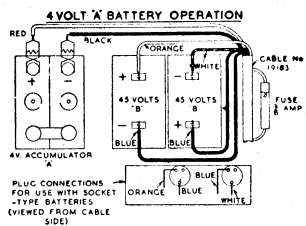

BATTERY CONNECTIONS.

## ALIGNMENT PROCEDURE.

### Manufacturer's Setting of Adjustments.

The receiver is tested by the manufacturers with precision instruments, and all adjusting screws are sealed. Re-alignment should be necessary only when components in tuned circuits are repaired or replaced, or when it is found that the seals over the adjusting screws have been broken.

It is especially important that the adjustments should not be altered unless in association with the correct testing instruments listed below.

Under no circumstances should the plates of the ganged tuning capacitor be bent, as the unit is accurately aligned during manufacture and cannot be re-adjusted unless by skilled operators using specialised equipment.

For all alignment operations, connect the "low" side of the signal generator to the receiver chassis, and keep the generator output as low as possible to avoid A.V.C. action. Also, keep the volume control in the maximum clockwise position.

### Testing Instruments.

- (1) A.W.A. Junior Signal Generator, type 2R3911  
OR
- (2) A.W.A. Modulated Oscillator, type J6726.

If the modulated oscillator is used, connect a 0.25 megohm non-inductive resistor across the output terminals, and, for short-wave alignment, an additional 400 ohms non-inductive resistor in series with the "high" output lead of the instrument.

- (3) Output Meter.

The instrument recommended should have an output impedance of 12,000 ohms and a range of 5-3,000 milliwatts. The meter should be connected across the primary of the loudspeaker transformer with the voice-coil of the loudspeaker open-circuit.

If the output meter used is one which does not impress a load on the anode circuit of the output valve, it will not be necessary to open-circuit the voice-coil.

## ALIGNMENT TABLE.

Order	Connect "high" side of Generator to:	Tune Generator to:	Set Receiver Drive Drum Scale to:	Adjust for Maximum peak output:
1	1A7GT Grid*	455 Kc.	0†	L14 Core
2	1A7GT Grid*	455 Kc.	0	L13 Core
3	1A7GT Grid*	455 Kc.	0	L12 Core
4	1A7GT Grid*	455 Kc.	0	L11 Core
5	1A7GT Grid*	455 Kc.	0	L10 Core
Repeat the above adjustments until the maximum output is obtained.				
6	Aerial Terminal	600 Kc.	18	L.F. Osc. Core Adj. (L7)‡
7	Aerial Terminal	1500 Kc.	154	H.F. Osc. Adj. (C5)
8	Aerial Terminal	1500 Kc.	154	H.F. Aer. Adj. (C3)
Repeat adjustments 6, 7 and 8.				
9	Aerial Terminal	20 Mc.	157	H.F. Osc. Adj. (C8)§
10	Aerial Terminal	20 Mc.	157	H.F. Aer. Adj. (C4)¶

\* With grid clip connected. A 0.001 uF capacitor should be connected in series with the "high" side of the test instrument.

† Set right-hand edge of pointer at 0, with tuning capacitor plates fully meshed.

‡ Rock the tuning control back and forth through the signal.

§ Use minimum capacity peak if two can be obtained. Check to determine that C8 has been adjusted to correct peak by tuning the receiver to approximately 19.09 Mc., where a weaker signal should be received.

¶ Use maximum capacity peak if two can be obtained.

### Loudspeaker Service.

It is inadvisable to attempt loudspeaker repairs other than adjustment of the voice coil and replacement of the transformer. The fitting of a new cone or the replacement of a field winding should be done only by Service Departments suitably equipped to do the work.

To centre the voice coil first remove the dust cover. To do this, use a very sharp razor blade and cut the centre out of the dust cover, cutting just inside the edge of the voice coil former, which can be felt with the finger. Do not attempt to tear the cover from the cone. Loosen the suspension screws, insert three narrow paper "feelers" in the gap and re-tighten the suspension screws. The "feelers" should be approximately 3/16 inch wide and 0.006 inch thick.

After adjusting, test the loudspeaker, and, if satisfactory, fasten a replacement dust cover in place with latex rubber cement. (See "Mechanical Replacement Parts.")

### "Service Window."

A "Service Window" is provided in the base of the table model cabinet. The "Window" is normally covered with a perforated grille fastened by four knurled nuts. With the grille removed, it is possible to perform most servicing operations without removing the chassis from the cabinet.

### Chassis Removal and Replacement.

- (1) Remove the control knobs. The knobs on the front of the cabinet are each held by a set screw. To remove the Tuning Control knob at the side of the cabinet, proceed as follows:—

Table Model: The knob pulls straight off.

Console Model: Loosen the screws in the spindle coupling and part the spindle.

- (2) Disconnect the pointer from the dial drive cord, by unscrewing the thumb nut, and disconnect the cable from the loudspeaker. Also, disconnect the yellow and black dial lamp leads from the chassis.
- (3) Four bolts hold the chassis in the cabinet. Remove these and withdraw the chassis.

On replacing the chassis in the cabinet, care must be taken to connect the dial pointer correctly, as follows:—

- (1) Turn the Tuning Control fully anti-clockwise.
- (2) Bring the dial pointer to a position opposite a setting mark on the dial scale, below, and approximately 1/16 inch to the left of 2CR.
- (3) Connect the pointer to the top drive cord and tighten the thumb-screw.

### Tuning Drive Cord Replacement.

The accompanying diagram shows the route of the cord and the method of attachment. Whilst fitting the cord, keep it taut and adjust the length so that the tension spring measures approximately 2 inches long when fitted. The spring should be sheathed to prevent it from rattling against the drum.

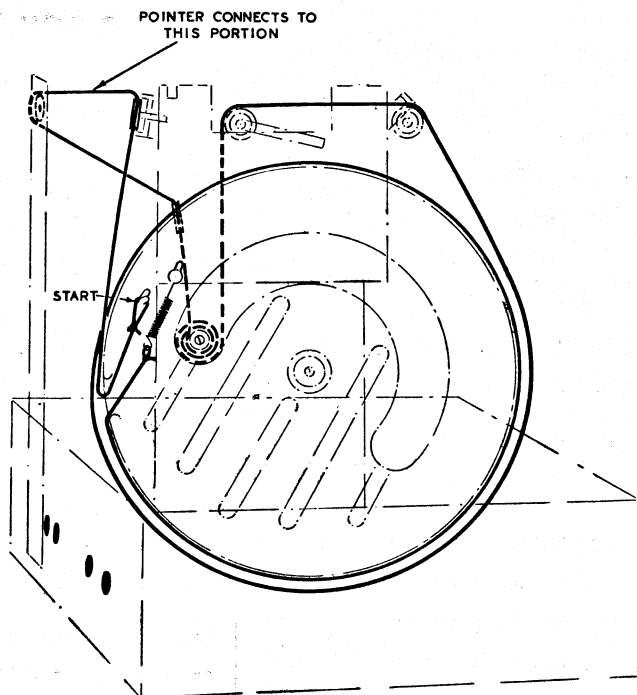

### SOCKET VOLTAGES AND CURRENTS

Valves	Bias Volts		Screen Grid to Chassis Volts		Anode to Chassis Volts		Anode Current mA		Filament Volts
	B.	V.	B.	V.	B.	V.	B.	V.	
1A7GT Converter .....	0	0	40*	40*	84	90	0.3	0.3	1.4
Oscillator, M.W. ....	—	—	—	—	50	50	0.8	0.8	—
S.W. ....	—	—	—	—	75	75	1.2	1.1	—
1P5GT I.F. Amplifier .....	0	0	84	90	84	90	1.3	1.5	1.4
1P5GT I.F. Amplifier .....	0	0	84	90	84	90	1.3	1.5	1.4
1H5GT Detector .....	0	0	—	—	50*	50*	0.03	0.03	1.4
1Q5GT Output .....	-6*	-4.5*	84	90	80	85	6	9	1.4

Measured with no signal input. Volume Control maximum clockwise.

\*These readings may vary, depending on the resistance of the voltmeter used.

### MECHANICAL REPLACEMENT PARTS.

Item	Part No.	Item	Part No.
<b>Receiver Chassis:</b>		Panel, terminal, 2 way .....	17386
Cabinet, Table Model .....	F5	Insulator .....	17387
Cabinet, Console Model .....	D3	Screen, I.F. transformer .....	3351
Cable, battery—		Cap .....	8372
4 volt } See "Electrical Specifications"		Screen, valve .....	9410
1.5 volt }		Cap .....	8148
Cable, loudspeaker—		Register .....	4733
Table Model .....	19186	Socket, 12 pin battery connection	
Console Model .....	19188	(female)—	
Cable, Volume Control .....	19180	Contact assembly .....	17760
Chassis-end—		Cover .....	17763
Left hand .....	19173	Ring, clamping .....	17764
Right hand .....	9901	Strip, insulating .....	17765
Clip, grid .....	7459	Clamp, cable .....	17776
Control Card, celluloid—		Socket, valve .....	4704
Left hand .....	19545	Socket, valve, cushion .....	7326
Right hand .....	19546	Spindle, tuning drive .....	19012
Dial frame assembly .....	19622	Spring, drive tension .....	6641
Dial lamp assembly .....	10224D	Strip, tag, 1-way .....	7628
Drum, drive .....	9090	2-way .....	8863
Dust cover, 7 inch loudspeaker .....	9843	3-way .....	4251
12 inch loudspeaker .....	10306	5-way .....	9210
Knob, small .....	4589	7-way .....	9879
large .....	8075	<b>Vibrator Power Unit No. 19190:</b>	
Mount plate assembly, tuning drive .....	19011	Cable, battery .....	19512
Plug, 12 pin, battery connection (male) .....	17757	Socket, vibrator .....	19510
Pulley, brass .....	1730	Strip, tag, 2-way .....	19511
		2-way, with lug .....	8021

ALIGNMENT TABLE

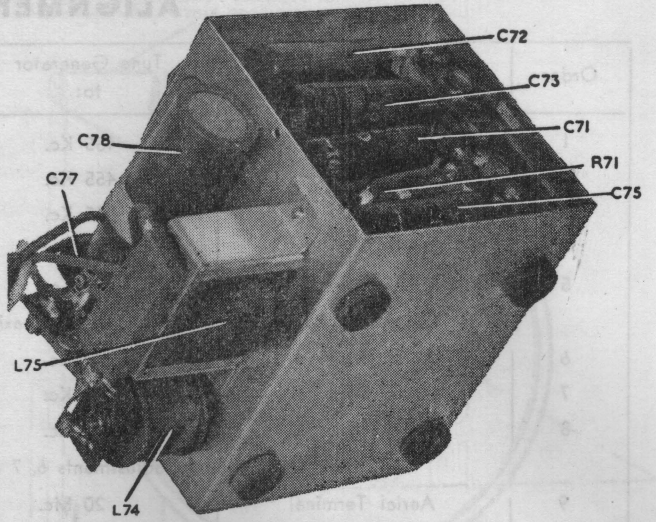
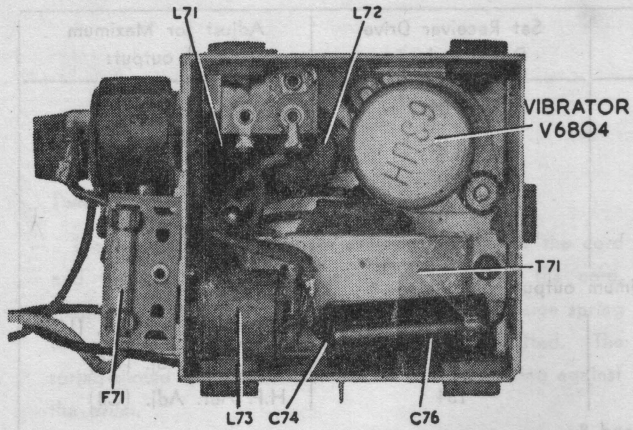

\* With grid connected. A 0.001 uf capacitor should be connected in series with the "high" side of the test instrument.

# CIRCUIT DIAGRAM

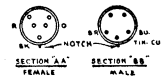
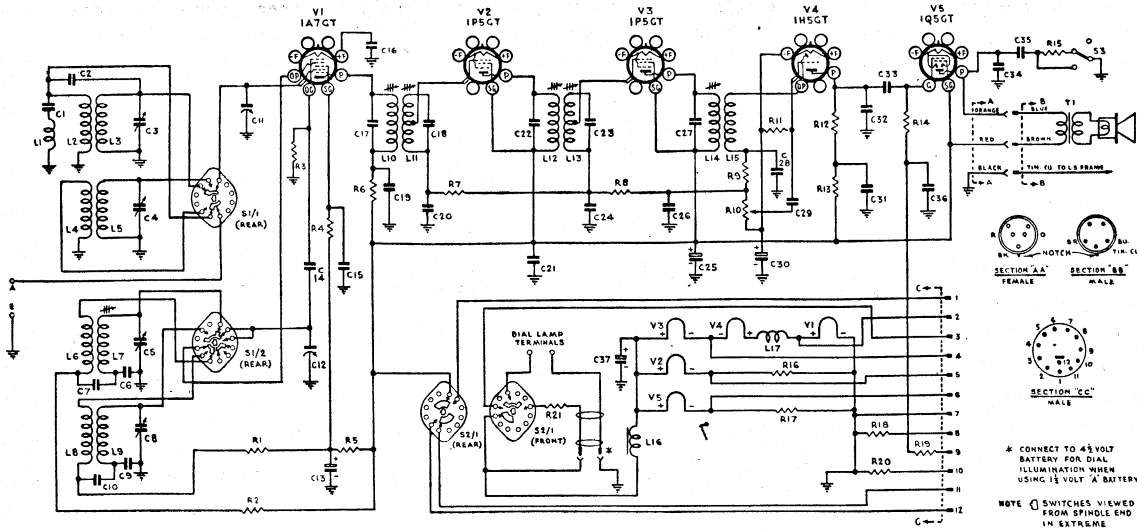

\* CONNECT TO 45 VOLT BATTERY FOR DIAL ILLUMINATION WHEN USING 1 1/2 VOLT "A" BATTERY

NOTE (1) SWITCHES VIEWED FROM SPINDLE END IN EXTREME ANTI-CLOCKWISE POSITION

PLUGS VIEWED FROM WIRING SIDE

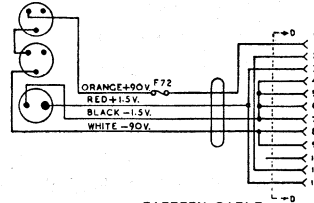

PLUGS VIEWED FROM WIRING SIDE

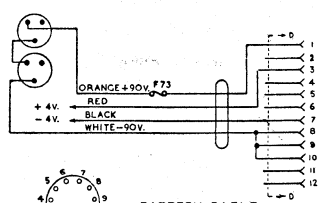

## VIBRATOR POWER UNIT No. 19190

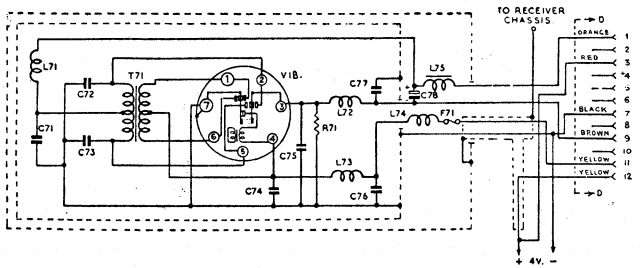



# CIRCUIT CODE

Circuit Code No.	Description	Stock Code or Part No.	Circuit Code No.	Description	Stock Code or Part No.	Circuit Code No.	Description	Stock Code or Part No.
<b>INDUCTORS.</b>						<b>RESISTORS.</b>		
L1	I.F. filter choke (including C1)	9382	C17	115 uuF silvered mica	226, 257	R1	400 ohms, ½ watt	600, 273
L2, L3	Aerial coil, 1600-550 Kc.	7974	C18	130 uuF silvered mica	226, 265	R2	40,000 ohms, 1 watt 600, 513 or 600, 713	
L4, L5	Aerial coil, 22-7 Mc.	9569	C19	0.1 uF paper, 400 V. working	228, 121	R3	0.1 megohm, ¼ watt	600, 121
L6, L7	Oscillator coil, 1600-550 Kc.	7638	C20	0.05 uF paper, 400 V. working	228, 115	R4	63,000 ohms, 1 watt 600, 517 or 600, 717	
L8, L9	Oscillator coil, 22-7 Mc.	9570	C21	0.5 uF paper, 400 V. working	228, 135	R5	5000 ohms, 1 watt 600, 495 or 600, 695	
L10, L11	1st I.F. transformer	6076Z, 6075*	C22	115 uuF silvered mica	226, 257	R6	400 ohms, ½ watt	600, 273
L12, L13	2nd I.F. transformer	5688Z, 5689*	C23	130 uuF silvered mica	226, 265	R7	0.1 megohm, ¼ watt	600, 121
L14, L15	3rd I.F. transformer	5959Z, 5758*	C24	0.05 uF paper, 400 V. working	226, 115	R8	1.6 megohms, ¼ watt	600, 145
L16	Smoothing choke	8243	C25	20 uF, 200 P.V. electrolytic	EE10725	R9	50,000 ohms, ¼ watt	600, 115
L17	R.F. choke	3149	C26	100 uuF mica	224, 261	R10	0.5 megohm Volume Control	10176
L71	R.F. choke	13809	C27	70 uuF silvered mica	226, 460	R11	10 megohms, 1 watt 600, 561 or 600, 761	
L72	R.F. choke	13809	C28	100 uuF mica	224, 261	R12	1 megohm, 1 watt 600, 541 or 600, 741	
L73	R.F. choke	3149	C29	0.01 uF paper, 600 V. working	228, 301	R13	0.2 megohm, 1 watt 600, 527 or 600, 727	
L74	R.F. choke	3149	C30	400 uF, 12 P.V. electrolytic	ET1045	R14	0.5 megohm, ¼ watt	600, 135
L75	R.F. choke	8321	C31	0.1 uF paper, 400 V. working	228, 121	R15	10,000 ohms, ¼ watt	600, 101
<b>CAPACITORS.</b>			C32	100 uuF mica	224, 261	R16	56 ohms, wire wound, 3 watt	610, 556
C1	50 uuF silvered mica	226, 155	C33	0.01 uF paper, 600 V. working	228, 301	R17	26 ohms, 3 watt, W.W. ± 5%	610, 526
C2	4 uuF mica	224, 233	C34	0.0025 uF paper, 600 V. working	228, 289	R18	500 ohms, ¼ watt	600, 075
C3	2-20 uuF air trimmer	3661	C35	0.02 uF paper, 600 V. working	228, 307	R19	0.5 megohm, ¼ watt	600, 135
C4	6-24 uuF air trimmer	5435A	C36	0.1 uF paper, 400 V. working	228, 121	R20	500 ohms, ¼ watt	600, 075
C5	11-29 uuF air trimmer	3411B	C37	400 uF, 12 P.V. electrolytic	ET1045	R21	7 ohms, 3 watt, W.W.	610, 507
C6	440 uuF mica, ± 2½% (padder)	13212†	C71	0.01 uF paper, 600 V. working	228, 301	R71	150 ohms, 1 watt, W.W.	610, 105
C7	0.05 uF paper, 400 V. working	228, 115	C72	0.02 uF paper, 600 V. working	228, 307	<b>TRANSFORMERS.</b>		
C8	2-10 uuF air trimmer	3658	C73	0.02 uF paper, 600 V. working	228, 307	T1	Loudspeaker transformer (table model)	XA7
C9	4000 uuF mica, ± 2½% (padder)	13213†	C74	0.1 uF paper, 400 V. working	228, 121		Loudspeaker transformer (console model)	TX8
C10	0.05 uF paper, 400 V. working	228, 115	C75	0.01 uF paper, 600 V. working	228, 301	T71	Vibrator transformer	17568
C11	12-430 uuF variable tuning (ganged)	19175	C76	0.1 uF paper, 400 V. working	228, 121	<b>SWITCHES.</b>		
C12	12-430 uuF variable tuning (ganged)	19175	C77	0.01 uF paper, 600 V. working	228, 301	S1	Range, 2 wafer, 2 position, rotary	19184
C13	20 uF, 200 P.V. electrolytic	EE10725	C78	20 uF, 200 P.V. electrolytic	EE0839	S2	Battery, 1 wafer, 3 position, rotary	19177
C14	50 uuF mica	224, 255				S3	Tone, 1 wafer, 3 position, rotary	19178
C15	0.1 uF paper, 400 V. working	228, 121				<b>FUSES.</b>		
C16	0.5 uF paper working	228, 135				F71	Cartridge, 3 Amp.	370, 011
						F72	Cartridge, ¼-¾ Amp.	370, 004
						F73	Cartridge, ¼-¾ Amp.	370, 004

\* Part number of winding only.

† Capacitance and tolerance (if shown) to be quoted.